

EDGETAK User Manual



Model 095-16200-EDGETAK

Engineering Design Team, Inc.

Version 1.2



EDT | Engineering Design Team, Inc.

3423 NE John Olsen Ave

Hillsboro, OR 97124 U.S.A.

Tel: +1-503-690-1234 | Toll free (in U.S.A.): 800-435-4320

Fax: +1-503-690-1243

<https://edt.com>

EDT is a subsidiary of [HEICO Corporation](#).





Warnings and Restrictions

- Overvoltage will damage the device. **DO NOT** apply more than 16V on the 12V input pins.
- Not FCC tested.
- Not tested by any safety agency.
- Intended for use with approved battery, AC adapter, or car adapter (up to user's discretion).
- User serviceable modules should only be serviced by trained technicians following instructions.
- Unit must be assembled with properly installed Thermal Interface Material (TIM)
- Disassembling or altering the enclosure may reduce the effectiveness of dust and water resistance.
- Do not reprogram with any operating system other than the EDT-provided board support package.
- Do not submerge in liquid.
- Do not allow enclosure vents to become covered or clogged.
- Intended for vertical use (connectors and face plate pointed upwards) and/or with airflow.
- Not intended for operation in ambient temperatures over 45°C.
- Requires adequate ventilation to achieve maximum processing capability.
- Store in temperatures between 18°C and 30°C for long term, or -40°C and 85°C for short term.
- We do not recommend disabling SOM protection capabilities.
- Designed for IP54, protection against dust ingress and splashes of water.
- Do not subject to high impact forces.
- Unless explicitly stated otherwise, this product and its accompanying documentation are subject to EDT's Terms of Use: <https://edt.com/downloads/edt-terms-use/>



Disclaimers

Engineering Design Team (EDT) provides the enclosed product under the following conditions:

This device is for evaluation purposes. Persons handling this product must have electronics training and observe good engineering practices. The enclosed device does not fall within the scope of the European Union directives regarding electromagnetic compatibility, restricted substances (RoHS), recycling (WEEE), FCC, CE or UL, and therefore may not meet the technical requirements of these directives or other related directives.

Product(s) and Documentation, including this document, are subject to change without notice. Documentation does not represent a commitment from EDT.

Warranty information: EDT standard warranty. <https://edt.com/downloads/edt-warranty/>

The user assumes all responsibility and liability for proper and safe handling of the product. Further, the user indemnifies EDT from all claims arising from the handling or use of the product. Due to the accessibility of the circuitry in this device, it is the user's responsibility to take any and all appropriate precautions with regard to static discharge. Except to the extent of the indemnity set forth above, neither party shall be liable to the other for any indirect, special, incidental, or consequential damages.

EDT assumes **no liability for applications assistance, customer product design, software performance, or infringement of patents or services described herein.** Please read the User's Guide and, specifically, the Warnings and Restrictions notice in this document prior to handling the product. This notice contains important safety information about temperatures and voltages. No license is granted under any patent right or other intellectual property right of EDT covering or relating to any machine, process, or combination in which such EDT products or services might be or are used.

FCC Warning

This device is intended for evaluation purposes only and is not considered by EDT to be the final end product for customer use. It may generate or use and can radiate radio frequency energy and has not been tested for compliance with the limits of computing devices pursuant to part 15 of FCC rules, which are designed to provide reasonable protection against radio frequency interference. Operation of equipment in other environments may cause interference with radio communications, in which case the user at his own expense will be required to take whatever measures may be required to correct this interference.

Trademarks

- Arm®, AMBA and ARM Powered are registered trademarks of [Arm Limited](#). Cortex, MPCore and Mali are trademarks of ARM Limited. "ARM" is used to represent ARM Holdings plc; its operating company ARM Limited; and the regional subsidiaries.



- Bluetooth® is a trademark of the [Bluetooth Special Interest Group](#) (Bluetooth SIG)
- DisplayPort™ is a trademark of [Video Electronics Standards Association](#) (VESA)
- HDMI, the HDMI logo, and High-Definition Multimedia Interface are trademarks or registered trademarks of HDMI Licensing LLC.
- Linux® is the registered trademark of Linus Torvalds in the U.S. and other countries.
- NVIDIA, the NVIDIA logo, Jetson Xavier, and Xavier are trademarks and/or registered trademarks of NVIDIA Corporation in the U.S. and other countries.
- PCIe® is a trademark of the [PCI Special Interest Group](#) (PCI-SIG)
- Wi-Fi® is a trademark of the [Wi-Fi Alliance](#)
- Other company and product names may be trademarks of the respective companies with which they are associated.





Table of Contents

- 1. Overview 6
- 2. Included in Package 8
- 3. To Access Modules 9
- 4. To Remove Modules 10
- 5. Installing Modules 11
- 6. Thermal Interface Material (TIM) 12
 - 6.1. EDGETAK Top TIM 12
 - 6.2. EDGETAK Bottom TIM 14
- 7. M.2 E-Key (Customer Supplied) 15
- 8. USB Type C Connectors 16
- 9. Once programmed, Display is used to create login - only the first time after install 16
- 10. USB C and DisplayPort adapters tested 17
- 11. Power Connector - 1 meter pigtail 18
- 12. Troubleshooting 19
 - 12.1. Unit is not powering on 19
 - 12.2. Unit is getting too hot or throttling 19
 - 12.3. RJ45 LEDs do not light up 19
 - 12.4. No Wi-Fi or Bluetooth 19
 - 12.5. No GPS 20
- Appendix A: Enclosure Screws 21
 - A.1. Clamshell screws 21
 - A.2. Face plate screws 21
- Appendix B: Revision History 22
- References 22





1. Overview

- User provides 12V DC supply
 - 9-16V DC input
 - Maximum current draw 6.0 Amps at 12 Volts
 - Recommended battery capacity 2.5Ah per 1 hour of intended intensive use or 1Ah per 1 hour of intended low load use (no intensive processing or data recording)
- Product dimensions: 88mm x 54mm x 213mm
- Weight: 2.35lbs/1.1kg
- Power connector for custom cable assembly
- Two SMA connectors available for connecting antennas to M.2 E-Key card
 - User must connect internal coax cable to the M.2 card
 - If the desired M.2 card has incompatible antenna connectors, user must replace internal coax cables with IP67 rated SMA cables
- 1x 1GbE port
- 2x USB Type C

For adequate cooling:

- Enclosure is recommended to be used in a vertical position with airflow.
- EDGETAK should not be used for intensive processing in a small, enclosed space with little airflow.
- If EDGETAK is used in high ambient temperatures or for processing heavy loads, it may throttle to protect itself.



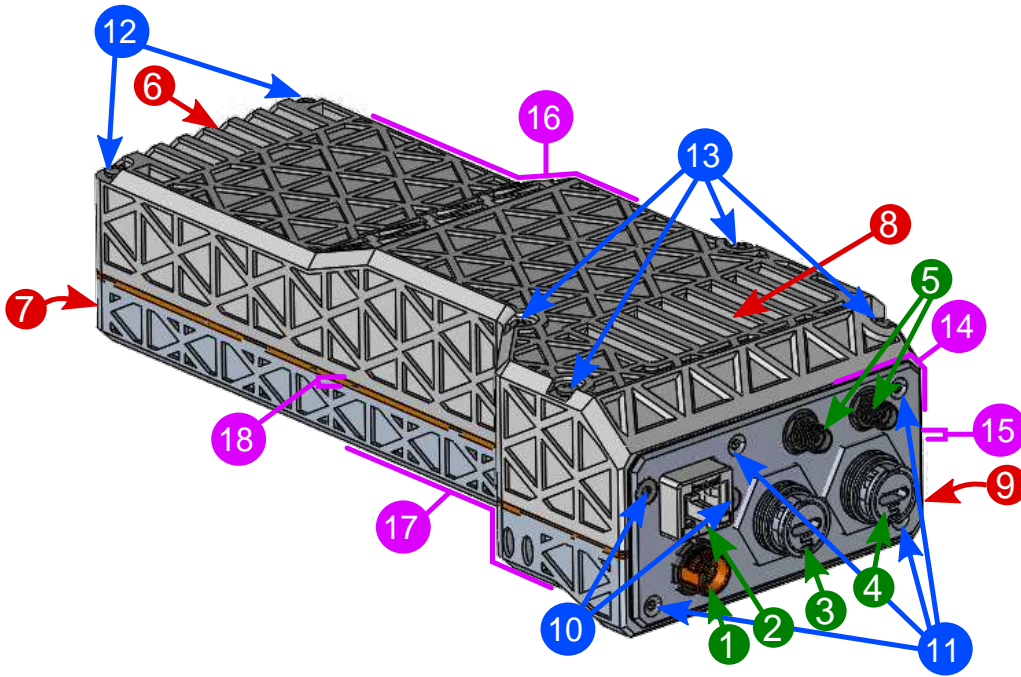

Figure 1. Components of an EDGETAK rev01

- 1. ● Power inlet connector
- 2. ● RJ45 1GbE Ethernet
- 3. ● USB Connector 2 (USB 3.2, NX Recovery)
- 4. ● USB Connector 1 (USB 3.2, DisplayPort)
- 5. ● (2x) SMA connectors for M.2 E-key antennas
- 6. ● Ventilation - intake, module side
- 7. ● Ventilation - intake, component side
- 8. ● Ventilation - exhaust, module side
- 9. ● Ventilation - exhaust, component side
- 10. ● (2x) Face plate screws, Torx T8, 4-40 14"
- 11. ● (4x) Face plate screws, Torx T8, M3.5x0.45
- 12. ● (2x) Enclosure screws, Phillips, M2.5x0.45 30mm
- 13. ● (4x) Enclosure screws, Phillips, M2.5x0.45 35mm
- 14. ● Face plate
- 15. ● Face plate gasket
- 16. ● Enclosure, module side (top)
- 17. ● Enclosure, component side (bottom)
- 18. ● Enclosure gasket



2. Included in Package

EDGETAK unit:

- NVIDIA Jetson Orin NX 16GB SOM
 - Board support package already programmed by EDT. May need display connected (via USB-C adapter) to create a Linux user account.
- Samsung EVO 990 2TB NVMe SSD
 - NVIDIA Jetson Linux + BSP already flashed
- SMA Cables 2x 200mm long IP67 to AMC (U.FL, MHF) connector for user antenna
 - User must install a E-key card and plug cables into card!
- Unit comes with single-end-terminated power cable, user adds desired source connector
- 2x USB C cables Samtec **BCU-C-S-1.00-UC-P**

Does not include:

- M.2 E-Key wireless card
- Antennas
- Power source and its connector
- Ethernet cable
- DisplayPort adapter

Table 1. Replacement Part Kits

Item	EDT Part No.
Screws	094-16229
Power Cable	016-16206
Faceplate	017-16179
Gaskets	094-16230
USB Cable	016-16183
SOM/SSD	094-16231



3. To Access Modules

Required tools and parts:

- Phillips screwdriver
- Torx T8 driver
- If disconnecting antenna cables, the appropriate unmating tool
 - for MHF I — I-PEX 90224-001 "MHF I Mating/Unmating Tool"
 - for MHF 4 — I-PEX 90435-001 "MHF 4 Mating/Unmating Tool"
 - for U.FL — Hirose U.FL-LP-N-2(01) "Tool extract for U.FL plug"
- Thermal Interface Material (TIM)
- Gaskets



TIM and gaskets can be re-used, but only if in good working condition.



Do not cross-thread screws. When inserting a screw into aluminum threads, always turn the screw backwards by hand first until it drops into the existing threads. Inserting a screw and beginning to tighten it, by hand or with an electric driver, may strip the threads in the aluminum

1. Remove at least the top two Torx T8 screws from the faceplate as shown in [Figure 2](#).
2. Remove six outer screws from larger half of the enclosure with Phillips screwdriver as shown in [Figure 3](#).

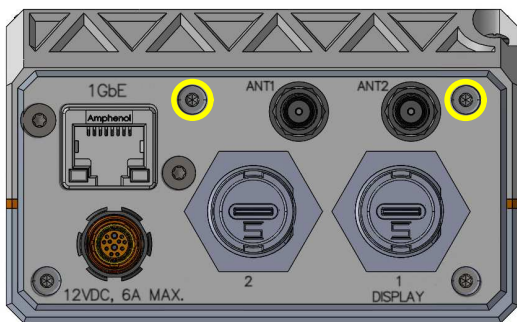

Figure 2. EDGETAK face plate screws connected to enclosure top (see also [Figure 14](#))

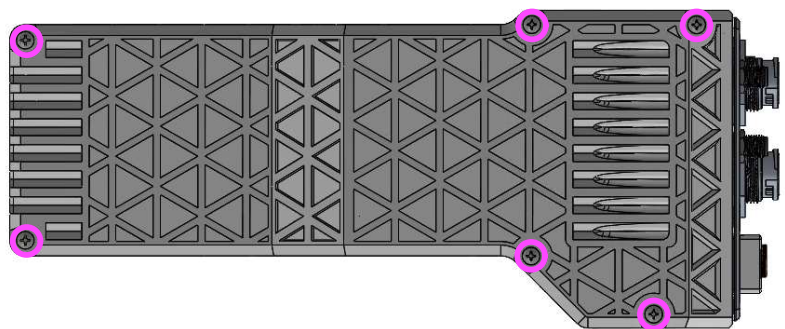

Figure 3. EDGETAK clamshell top screws (see also [Figure 13](#))

4. To Remove Modules

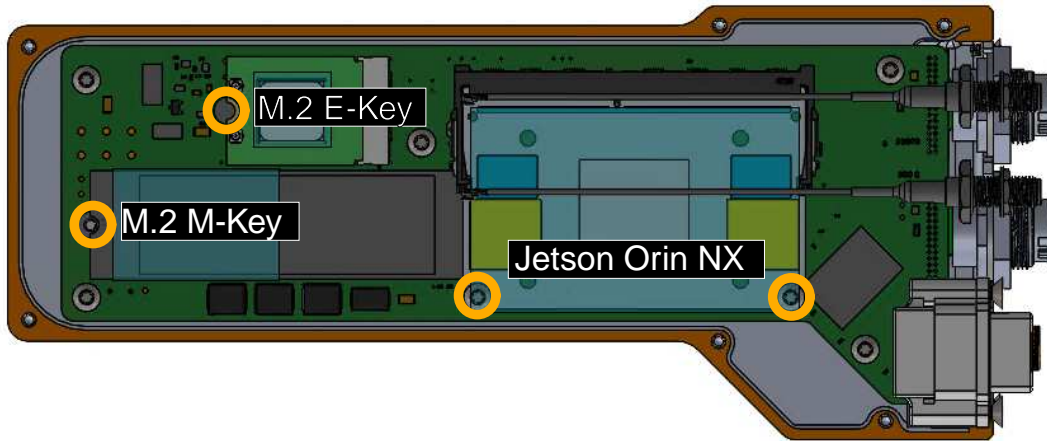

Figure 4. EDGETAK internal module screws

M.2 E-key:

1. Carefully disconnect any antenna cables attached to the module's RF connectors (e.g U.FL, MHF I, MHF 4) with the appropriate tool. See suggested tools in [Section 3](#).
2. Unscrew one Phillips screw and remove M.2 card by pulling it away from the connector.
3. Leave the Kapton tape (translucent brown/orange) on the board, to prevent shorts when another E-Key module is installed.

M.2 M-Key:

1. Unscrew one Phillips screw.
2. Raise card to a 30 degree angle then pull away from connector.

Jetson Orin NX SoM:

1. Unscrew 2x Phillips screws from standoffs (standoffs remain installed).
2. Nudge the side arms of the SODIMM connector out by a small amount to release the NX.
3. Raise NX module to a 30 degree angle then pull away the SODIMM connector.



5. Installing Modules

- Be sure each module is fully seated and even.
- Ensure there is Kapton tape under the E-Key card to avoid shorts.
- Replace all TIM according to the instructions in section [Section 6.1](#).
- Route the SMA cables so they are not damaged when the enclosure is sealed or interfere with any TIM.
- Make sure gasket material is adhered to the component half (smaller side) of the enclosure along the provided inner lip and that the screw holes are clear.
- Install 4 module screws as shown in [Figure 4](#).
- Add TIM (minimum Orin NX chip in middle and NVMe SSD)
 - Ensure that the protective plastic is removed from **BOTH** sides of the TIM.
- Install 6 long Philips screws to seal enclosure as shown in [Figure 13](#).
- Install 4 Torx T8 screws to affix the faceplate to the two assembled enclosure halves as shown in [Figure 14](#). Gasket material should have remained adhered to the back of faceplate, ensure that screw holes are free of gasket material.



6. Thermal Interface Material (TIM)

If the thermal interface material is damaged or otherwise needs to be replaced, follow these instructions to correctly replace it for proper thermal performance. Do not reuse uneven, damaged, or over-compressed TIM material. Unless explicitly marked "optional", TIM must be present at all sites 'A' through 'Q' and must use the TIM sizes and thicknesses identified in [Table 2](#) and [Table 3](#).



Make sure to remove plastic cover from **BOTH** sides of TIM before application!



Gasket must be undamaged and properly installed to preserve any environmental protection!

6.1. EDGETAK Top TIM

Install TIM sites **G** through **Q** onto modules, not the enclosure.

Table 2. TIM Sites and Dimensions: EDGETAK board top

Site	Thickness (mm)	Dimensions (mm ²)
G	2.5	40 x 22
H	1	16 x 22
I, M	2	5 x 5
J, N	1	14 x 14
K, O	2	10 x 7
L, P	4	7 x 7 (<i>optional</i>)
Q	1	23 x 21

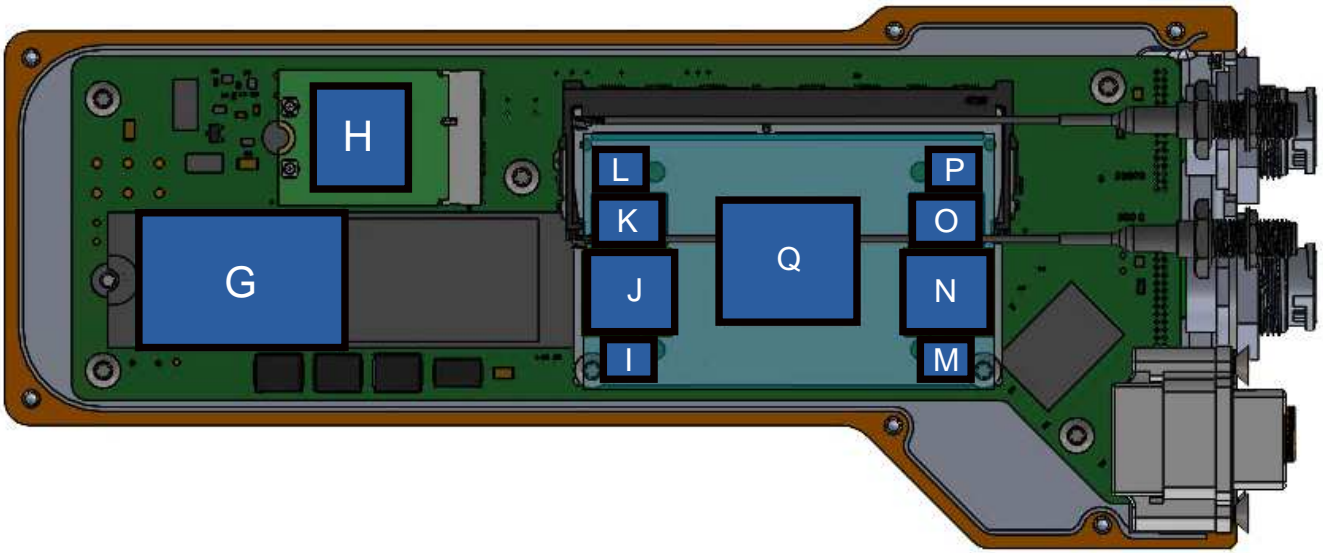

Figure 5. TIM sites on EDGETAK board top

6.2. EDGETAK Bottom TIM

Don't take the board out of the smaller half/bottom of the clamshell enclosure ...but if you do, put TIM back on!

- Route the power connector wires carefully in the designated channel.
- Install 6x Torx T10 screws, careful to not cross-thread the aluminum threads!

Table 3. TIM Sites and Dimensions: EDGETAK case bottom

Site	Thickness (mm)	Dimensions (mm ²)
A	0.5	7 x 9
B	0.5	7 x 7
C	1	7 x 7
D	0.5	5 x 9
E	1	10 x 10
F	2.5	12 x 11

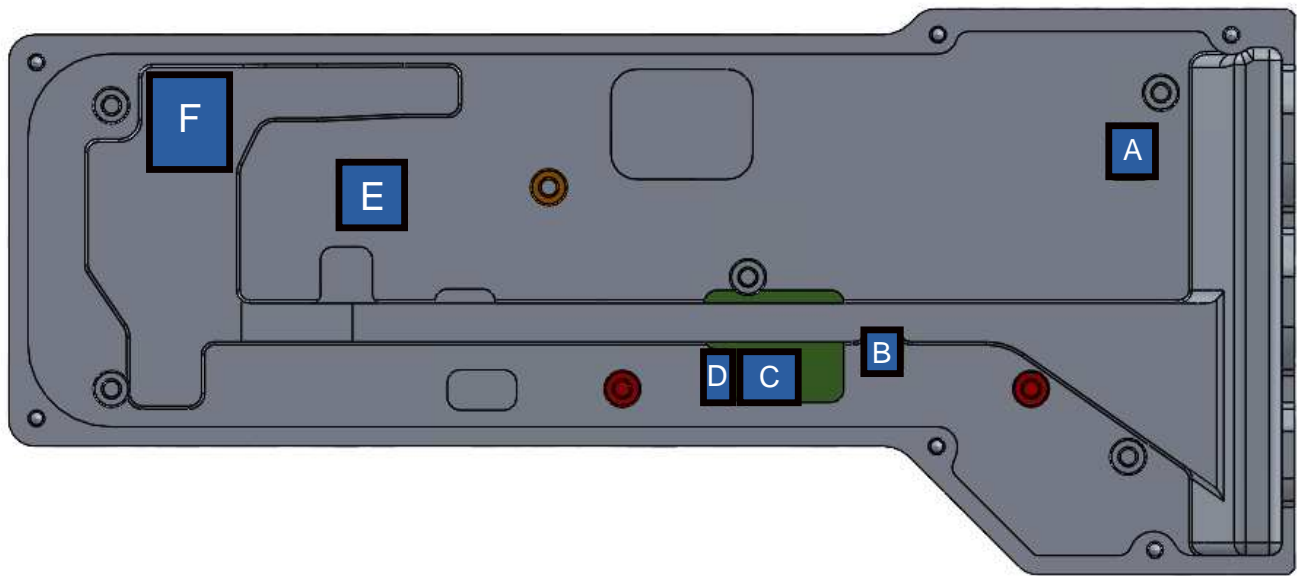

Figure 6. TIM sites on EDGETAK clamshell enclosure bottom



7. M.2 E-Key (Customer Supplied)

- User provides antenna and E-key card.
- Always cover the PCB under the M.2 E-Key module with Kapton tape before use to avoid shorts.
- Can replace SMA connectors with other to match E-key connectors.
 - Alternate or replacement SMA cables EDT suggests:
 - SMA to AMC 200mm from Amphenol [336319-12-0200](https://www.amphenolrf.com/336319-12-0200.html) (used by EDT)
 - SMA to AMC4 200mm from Amphenol [095-902-502-200](https://www.amphenolrf.com/095-902-502-200.html)
 - SMA to MHF 200mm from Amphenol [095-902-585-200](https://www.amphenolrf.com/095-902-585-200.html)
- Wi-Fi/Bluetooth card tested:
 - Intel Wi-Fi 6 AX200 (Gig+), ordering code [AX200.NG.WG.DTK](#)
- GPS card that exists:
 - Auvideo M.2 Key B/E GPS module Model# 70899
<https://auvideo.eu/product/gps-70899/>

Reference antenna connector compatibility chart below:

Table 4. Antenna (RF Coaxial) Connector Compatibility [1]

Amphenol	PCB Footprint	Mated Height	Compatibility
AMC	3 mm x 3 mm	2.5 mm	Hirose U.FL I-PEX MHF I / MHF
AMC4	2 mm x 2 mm	1.4 mm	I-PEX MHF 4
AMMC	2 mm x 2 mm	1.4 mm	Hirose W.FL I-PEX MHF III / MHF 3



8. USB Type C Connectors

Connector 1

- USB 3.2, up to 10 Gbps
- DisplayPort over USB-C (DP Alt Mode)
- USB PD sources power up to 7.5W (5.0V 1.5A)

Connector 2

- USB 3.2, up to 10 Gbps
- Recovery Programming port (short jumper J8)
- USB PD sources power up to 7.5W (5.0V 1.5A)

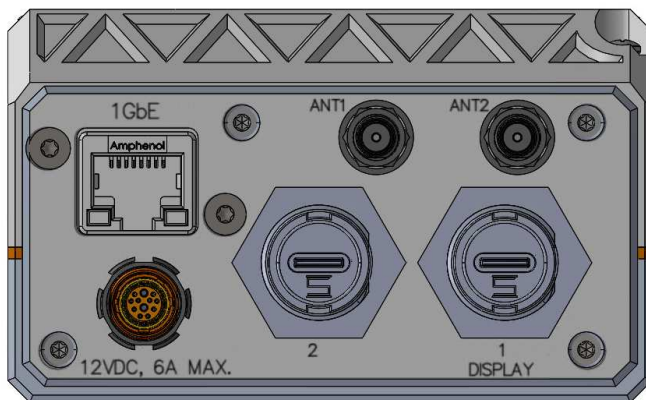

Figure 7. EDGETAK faceplate showing USB C connectors 1 and 2

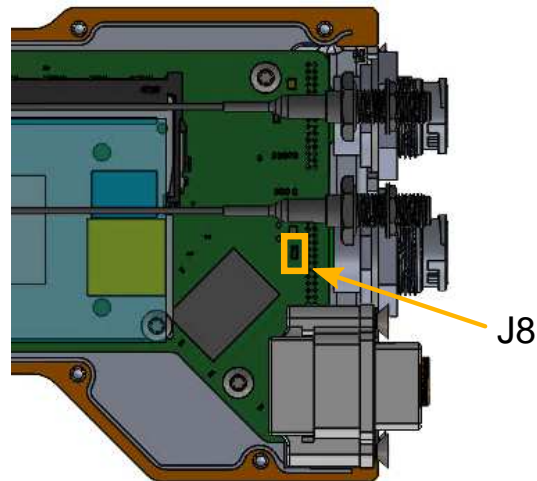

Figure 8. Jumper J8 on EDGETAK board

9. Once programmed, Display is used to create login - only the first time after install

- Connect DisplayPort display through USB Connector1 using an adapter or dock that supports DP Alt Mode.
- Using GUI, finish OS setup and create username and password.
- Then the device can be accessed via the graphical desktop, remotely over SSH, or locally with serial UART.

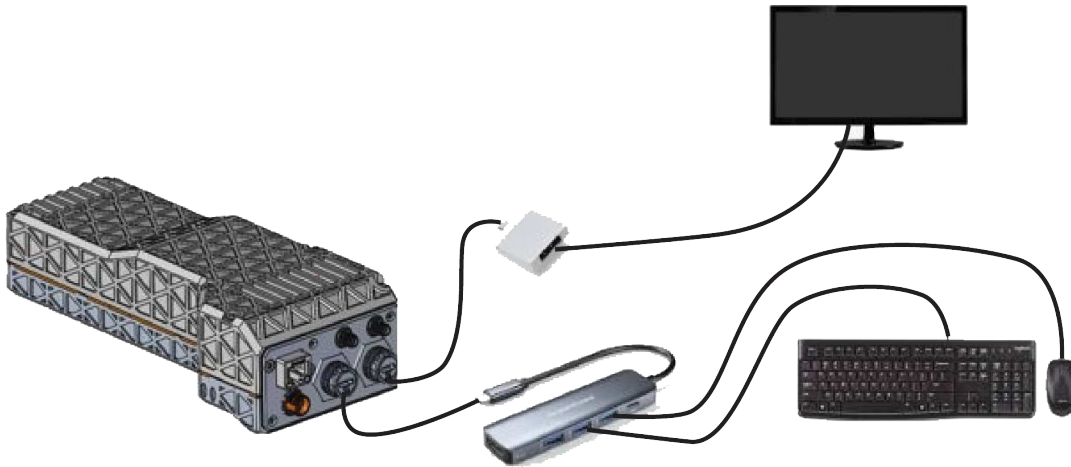

Figure 9. EDGETAK connected to display, keyboard, and mouse using USB C adapters

10. USB C and DisplayPort adapters tested

USB C Docks/Hubs

- Plugable Thunderbolt™ and USB-C Dual Monitor Docking Station, model TBT3-UDZ
<https://plugable.com/products/tbt3-udz>
- VisionTek VT2000 USB-C Dock, model 901284
<https://visiontek.com/products/vt2000-triple-display-usb-c-docking-station-with-power-passthrough>

Display Adapters

- Plugable USB-C to DisplayPort adapter, model USBC-TDP
<https://plugable.com/products/usbc-tdp>
- Plugable USB-C to HDMI 2.1 8K adapter, model USBC-HDMI8K
<https://plugable.com/products/usbc-hdmi8k>
- Framework DisplayPort Adapter (2nd gen)
<https://frame.work/products/displayport-2nd-gen-expansion-card>

Miscellaneous

- UGREEN NVMe Enclosure, model CM559
<https://www.ugreen.com/products/ugreen-m-2-nvme-sata-ssd-enclosure-adapter>

11. Power Connector - 1 meter pigtail

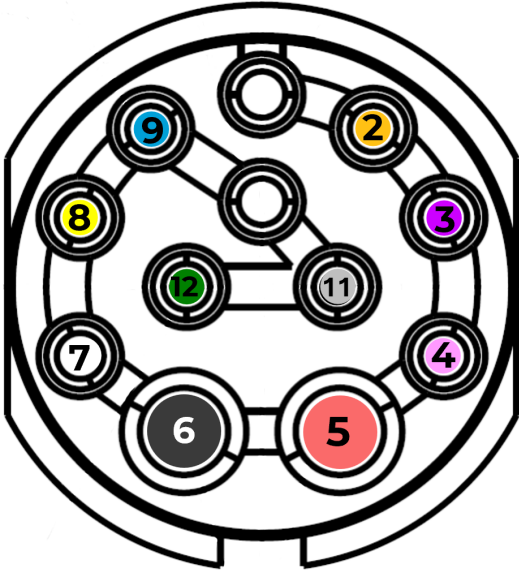

Figure 10. EDGETAK 12-pin ODU power connector pin numbering (viewed from front)

Table 5. EDGETAK 12-pin ODU cable pin/wire map

Pin	Color	Wire Gauge	Signal
1			n/c
2	Orange	28	MCU_RX
3	Purple	28	MCU_TX
4	Pink	28	VIN (12V)
5	Red	22	VIN (12V)
6	Black	22	GND
7	White	28	GND
8	Yellow	28	NX_TX
9	Blue	28	NX_RX
10			n/c
11	Mithril	28	VIN (12V)
12	Green	28	GND



Silkscreen labels on the EDGETAK rev01 board for NX UART RX and TX signals are swapped at P3 and P4.

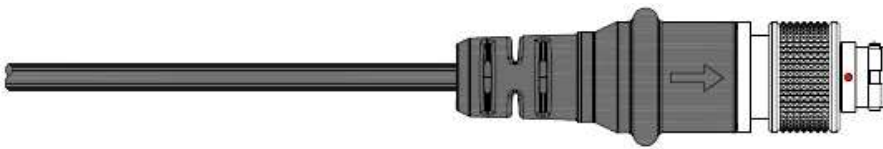

Figure 11. EDGETAK power cable with ODU 12-pin plug (male) connector



Figure 12. ODU 12-pin plug (male) connector [GC0WDM-PD1WMM0-000L](#)

12. Troubleshooting

12.1. Unit is not powering on

- Is the 12V power cable working? Test continuity.
- Is the recovery jumper shorting J8? Disconnect jumper or de-press pushbutton. Used only for programming OS.
- Has the unit been overvoltaged? May be damaged if over 17V.

12.2. Unit is getting too hot or throttling

Enclosure temperature hotter than about 122°F at 75°F ambient or 140°F at 113°F ambient?

- Check that there is no debris in the enclosure vents and air can flow.
- Increase airflow around/through enclosure.
- Could be a broken or defective unit.
- Reduce workload and/or lower NX power mode.

12.3. RJ45 LEDs do not light up

By default they are disconnected. Contact EDT for instructions if LEDs are desired by either reaching out to your EDT point of contact or email tech@edt.com.

12.4. No Wi-Fi or Bluetooth

- Ensure Wi-Fi card is installed in E-key slot.
- Ensure RF cables connected correctly to E-Key and faceplate.
- Ensure Antenna installed.
- Check if Wi-Fi modem appears in the `lspci` Linux tool output.
- Check if Bluetooth modem appears in the `lsusb` Linux tool output.
- If Intel 8265NGW, AX200, AX210 or similar is detected with `lspci` but no kernel driver is setting it up as a network interface, it may be because some Intel wifi drivers are no longer included in NVIDIA's kernel by default. Newer (backported) drivers are available from Ubuntu repositories:

```
apt install backport-iwlwifi-dkms
modprobe iwlwifi
```



12.5. No GPS



- Install a GPS card in M.2 E-Key slot (see [Section 7](#)), or use a GPS USB dongle.



Appendix A: Enclosure Screws

A.1. Clamshell screws

All six screws are M2.5x0.45 with a **Phillips** head, but the back two are slightly shorter.

-  EDT P/N [020-16189-00](#) Screw; PPH, M2.5x0.45, 30mm, S/S (McMaster-Carr [92000A065](#))
-  EDT P/N [020-16188-00](#) Screw; PPH, M2.5x0.45, 35mm, S/S (McMaster-Carr [92000A202](#))

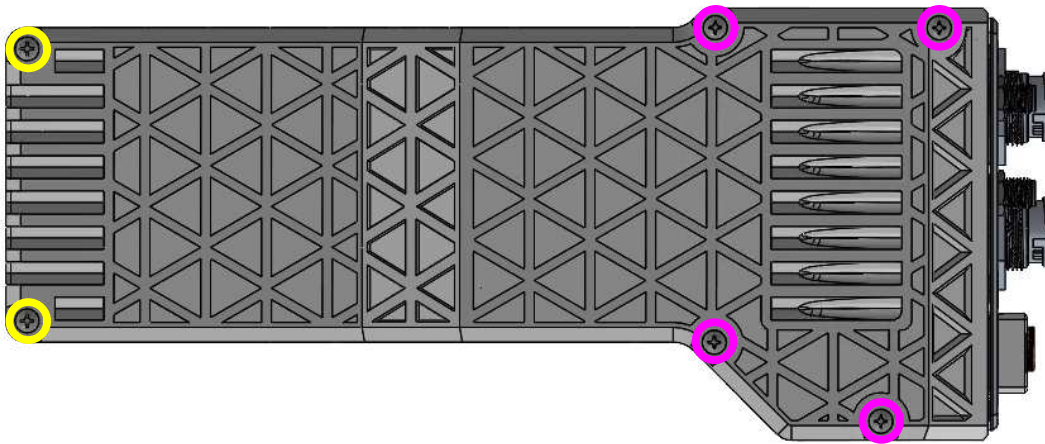



Figure 13. EDGETAK top clamshell enclosure screws

A.2. Face plate screws

All face plate screws have a **Torx T8** head.

-  EDT P/N [020-16190-090](#) Screw; Torx T8 FH, 4-40 Thread 1/4cm, S/S (McMaster-Carr [92703A205](#))
-  EDT P/N [020-16187-00](#) Screw; Torx T8 FH, M2.5x0.45, 6mm, S/S (McMaster-Carr [92703A158](#))

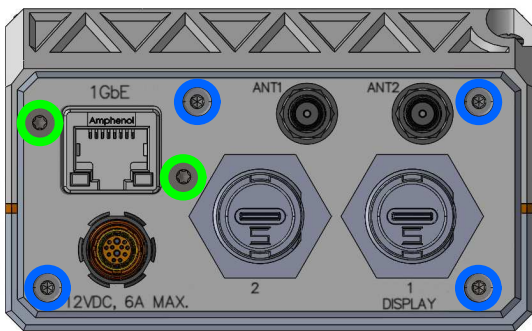

Figure 14. EDGETAK face plate screws



Appendix B: Revision History

Table 6. Revision History

Revision	Date	Author	Description
1.2	2025-11-11	AH	Change document generator tool. Layout and organizational changes. Fix USB C adapter links. Cite Amphenol RF compatibility table.
1.1	2025-08-19	CK	(pg 1, 12, 13) Updated product image, updated product links, updated pin table.
1.0	2024-08-10	BVW, CK	Initial release

References

- [1] Amphenol RF, "Ultraminiature Product Series," 6 April 2021. [Online]. Available: https://www.amphenolrf.com/library/download/link/link_id/591185/parent/A-4JA/ [Accessed: Nov. 11, 2025].

